

WARNING

- Use neutral detergent to clean the chain. Do not use alkali-based or acid based detergent such as rust cleaners as it may result in damage and/or failure of the chain.
- Use the reinforced connecting pin only for connecting the narrow type of chain.
- There are two different types of reinforced connecting pin available. Be sure to check the table below before selecting which pin to use. If connecting pins other than reinforced connecting pins are used, or if a reinforced connecting pin or tool which is not suitable for the type of chain is used, sufficient connection force may not be obtained, which could cause the chain to break or fall off.

Chain	Reinforced connecting pin	Chain tool
9-speed super narrow chain such as CN-7700 / CN-HG92	 6.5mm Silver	TL-CN31/TL-CN22
Chaîne étroite à 8/7/6 vitesses comme CN-HG50 / CN-IG51	 7.1mm Black	TL-CN31/TL-CN22 and TL-CN30/TL-CN21

- If it is necessary to adjust the length of the chain due to a change in the number of sprocket teeth, make the cut at some other place than the place where the chain has been joined using a reinforced connecting pin or an end pin. The chain will be damaged if it is cut at a place where it has been joined with a reinforced connecting pin or an end pin.

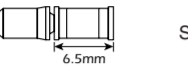
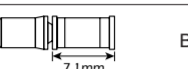
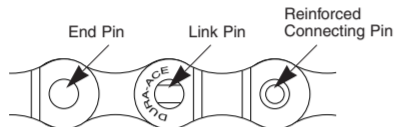

- Obtain, read and carefully service instructions when installing parts. A loose, worn, or damaged parts may cause injury to the rider. We strongly recommend that only genuine Shimano replacement parts be used.

CAUTION

- Use a front chainwheel which is compatible with 9-speed chains in conjunction with Shimano CN-7700, CN-HG92 and CN-HG72 chains. If a chainwheel for an 8-speed chain or less is used, front chainwheel gear shifting problems may occur, or the chain pins might fall out, causing the chain to break.

Note

- Apply grease to the bottom bracket before installing it.
- For smooth operation, use the specified outer casing and the bottom bracket cable guide.
- This front derailleur is for triple front chainwheel use only. It cannot be used with the double front chainwheel, as the shifting points do not match.
- When installing the top route type, choose a frame that has three outer casing holders as shown in the illustration at right.
- Use an outer casing which still has some length to spare even when the handlebars are turned all the way to both sides. Furthermore, check that the shifting lever does not touch the bicycle frame when the handlebars are turned all the way.
- Grease the inner cable and the inside of the outer casing before use to ensure that they slide properly.
- Use only the applicable chain and bottom bracket mentioned above.
- Operation of the levers related to gear shifting should be made only when the front chainwheel is turning.
- If the brake fluid used in the oil disc brakes is of a type which tends to adhere to the plastic parts of the shifting lever, this may cause the plastic parts to crack or become discolored. Therefore, you should make sure that the brake fluid does not adhere to these plastic parts. The mineral oil which is used in SHIMANO disc brakes does not cause cracking or discoloration if it adheres to plastic parts, but such parts should be cleaned with alcohol beforehand to prevent foreign particles from adhering.
- For maximum performance we highly recommend Shimano lubricants and maintenance products.
- For any questions regarding methods of handling or maintenance, please contact the place of purchase.

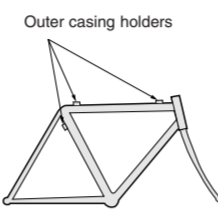

FD-M750/FD-M570 Adjustment Bolts

Because of the different construction of the new link, the positions of the top and low adjustment bolts on the FD-M750/FD-M570 are reversed from the positions on previous front derailleurs.

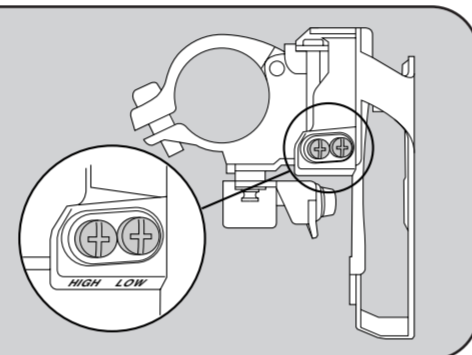

SERVICE INSTRUCTIONS

SI-F650D

Front Drive System

Before use, read these instructions carefully, and follow them for correct use.

In order to realize the best performance, we recommend that the following combination be used.

	DEORE-XT	DEORE-LX
Series	ST-M750 / SL-M750	ST-M570 / SL-M570
Rapidfire M9	SP40 sealed	SP40 sealed
Outer casing	FD-M750	FD-M570
Front derailleur	FC-M751	FC-M571
Bottom bracket	BB-ES70	BB-ES70
Chain	CN-HG92	CN-HG72
Bottom bracket cable guide	SM-SP17 / SM-BT17	SM-SP17 / SM-BT17

Specifications

Model number	FD-M751/FD-M750/ FD-M570	FD-M750-E / FD-M570-E	FD-M571
Normal type	○	○	○
Top route type	○	○	○
Front chainwheel tooth difference	22T	22T	22T
Min. difference between top and intermediate	12T	12T	12T
Front derailleur installation band diameter	S, M, L	S, M, L	S, M, L
Chainstay angle (α)	66° - 69°	66° - 69°	63° - 66°, 66° - 69°
Applicable chain line	47.5mm, 50.0mm	47.5mm, 50.0mm	47.5mm, 50.0mm
Applicable Bottom Bracket	BB-ES70	BB-ES70E	BB-ES70

Installation band diameters:
S (28,6 mm), M (31,8 mm), L (34,9 mm)

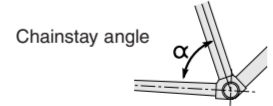

Chainwheel

Model number	FC-M751-4 Arm FC-M571-4 Arm
Chainwheel tooth combination	44-32-22T
Bolt circle diameter	104 mm / 64 mm
Crank arm length	170 mm, 175 mm
Pedal thread dimensions	BC 9/16" x 20 T.P.I.

Bottom Bracket

Model number	BB-ES70		BB-ES70E	
Spindle length	113 mm	118 mm	113 mm	118 mm
Chain line	47.5 mm	50 mm	47.5 mm	50 mm
Shell width	68, 70, 73 mm	68, 70, 73 mm	68 mm	73 mm
Thread dimensions	BC1.37 (68, 73mm) M36 (70mm)	BC1.37 (68, 73mm) M36 (70mm)	BC1.37 (68 mm)	BC1.37 (73 mm)

Installation of the Front Derailleur, Bottom Bracket and Front Chainwheel

FD-M750-E / FD-M570-E

Use the special tools (TL-UN70 and TL-UN74-S) to install the bottom bracket (1) and the front derailleur so that they face as shown in the illustration. Install the adapter (2), and then use an 8 mm Allen key (3) to install the front chainwheel. Secure by using the bolt (4).

Adapter / bottom bracket tightening torque:
50 - 70 Nm {435 - 608 in. lbs.}
Front chainwheel tightening torque:
35 - 50 Nm {305 - 435 in. lbs.}

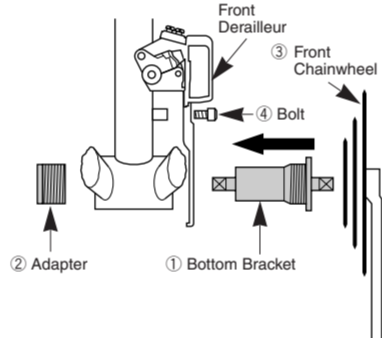

**FD-M570 / 571
FD-M750 / 751**

Install using the special tool TL-UN74-S. First install the main body, then the adapter.

Adapter / bottom bracket tightening torque:
50 - 70 Nm {435 - 608 in. lbs.}

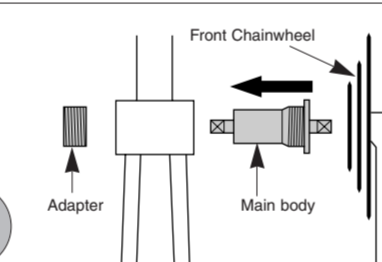

Use an 8 mm Allen key to install the front chainwheel.

Front chainwheel tightening torque:
35 - 50 Nm
{305 - 435 in. lbs.}

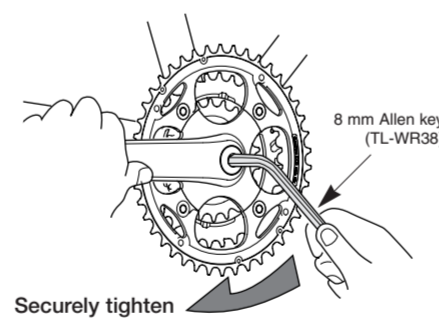

The level section of the chain guide outer plate should be directly above and parallel to the largest chainring. Secure using a 5 mm Allen key.

Tightening torque:
5 - 7 Nm {44 - 60 in. lbs.}

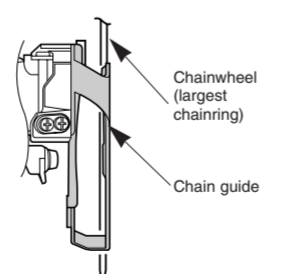

Adjust and then install the front derailleur as shown in the illustration. Do not remove the Pro-Set alignment block at this time.

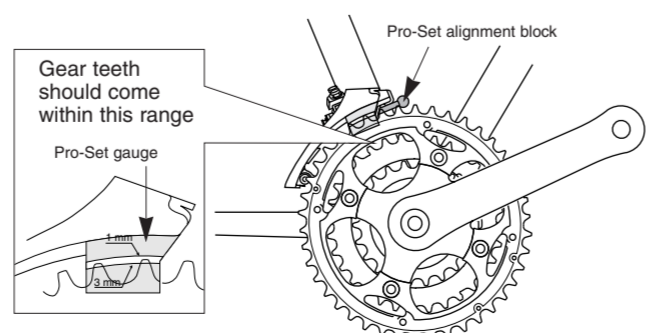

Chain length

Add 2 links (with the chain on both the largest sprocket and the largest chainring)

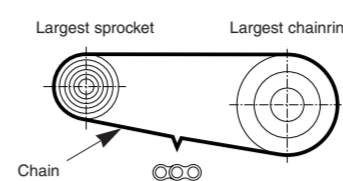

Mounting the shifting lever

Use a handlebar grip with a maximum outer diameter of 32 mm.

**ST-M750 /
ST-M570**

Tightening torque :
6 - 8 Nm {53 - 69 in. lbs.}

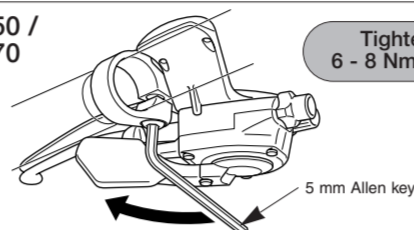

**SL-M750 /
SL-M570**

Tightening torque :
5 Nm {44 in. lbs.}

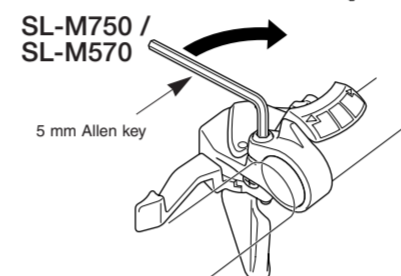

SIS adjustment

Be sure to follow the sequence described below.

1. Low adjustment

First remove the Pro-Set alignment block. Next, set so that the clearance between the chain guide inner plate and the chain is 0-0.5 mm.

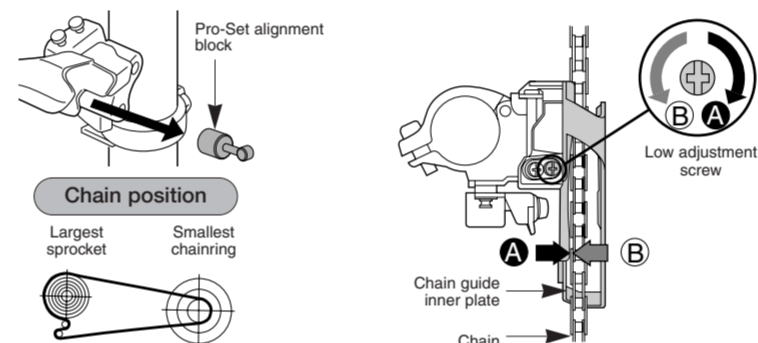

2. Connecting and securing the inner cable

Operate lever (B) two times or more, and check on the indicator that the lever is at the lowest position. Then remove the inner hole cover and connect the inner cable.

Tightening torque:
5 - 7 Nm {44 - 60 in. lbs.}

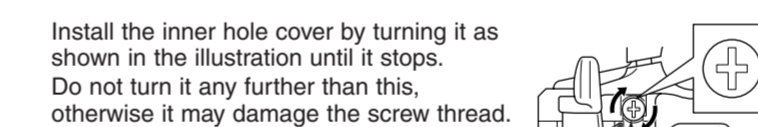

Tightening torque:
0.3 - 0.4 Nm {3 - 4 in. lbs.}

Inserting the inner cable

Insert the inner cable into the outer casing from the end with the marking on it. Apply grease from the end with the marking in order to maintain cable operating efficiency.

Cutting the outer casing

When cutting the outer casing, cut the opposite end to the end with the marking. After cutting the outer casing, make the end round so that the inside of the hole has a uniform diameter.

Attach the same outer end cap to the cut end of the outer casing.



Tightening torque:
5 - 7 Nm {44 - 60 in. lbs.}

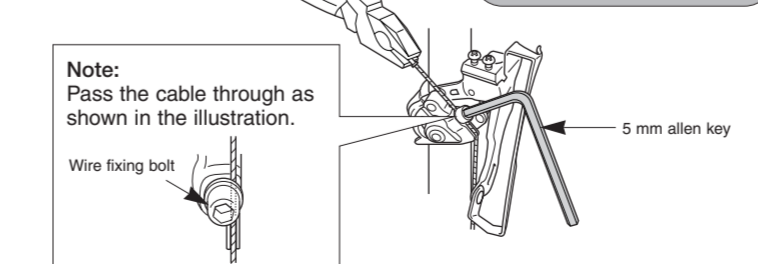

Note:
Pass the cable through as shown in the illustration.

After taking up the initial slack in the cable, re-secure to the front derailleur as shown in the illustration.

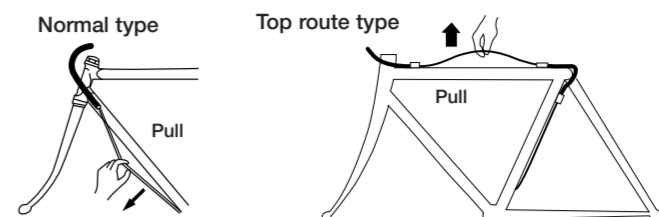

3. Top adjustment

Set so that the clearance between the chain guide outer plate and the chain is 0-0.5 mm.

Chain position

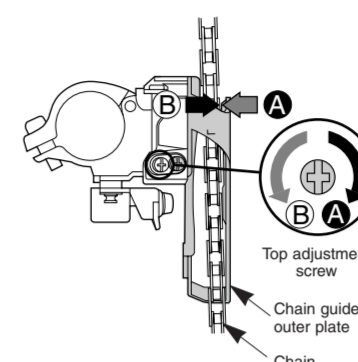
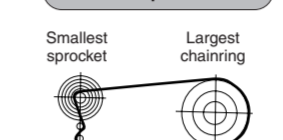

4. Adjustment of the intermediate chainring

When carrying out adjustment, set the chain to the largest sprocket, and at the front, set the chain to the intermediate chainring. Adjust using the outer casing adjustment barrel so that the clearance between the chain guide inner plate and the chain is 0-0.5 mm.

Chain position

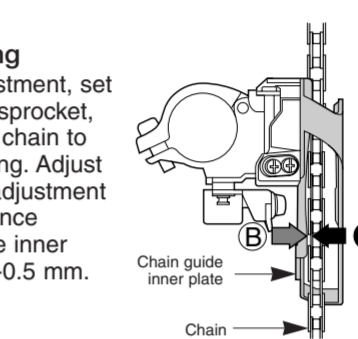
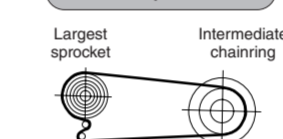

5. Troubleshooting chart

After completion of steps 1 - 4, move the shifting lever to check the shifting. (This also applies if shifting becomes difficult during use.)

If the chain falls to the crank side.	Tighten the top adjustment screw clockwise (about 1/4 turn).
If shifting is difficult from the intermediate chainring to the largest chainring.	Loosen the top adjustment screw counterclockwise (about 1/8 turn).
If shifting is difficult from the intermediate chainring to the smallest chainring.	Loosen the low adjustment screw counterclockwise (about 1/4 turn).
If there is interference between the chain and the front derailleur inner plate at the largest chainring.	Tighten the top adjustment screw clockwise (about 1/8 turn).
If there is interference between the chain and the front derailleur outer plate at the largest chainring.	Loosen the top adjustment screw counterclockwise (about 1/8 turn).
If the intermediate chainring is skipped when shifting from the largest chainring.	Loosen the outer casing adjustment barrel counterclockwise (1 or 2 turns).
If there is interference between the chain and front derailleur inner plate when the rear sprocket is shifted to the largest sprocket when the chainwheel is at the intermediate chainring position.	Tighten the outer casing adjustment barrel clockwise (1 or 2 turns).
If the chain falls to the bottom bracket side.	Tighten the low adjustment screw clockwise (about 1/2 turn).

Gear shifting operation

Both lever (A) and lever (B) always return to the initial position when they are released after shifting. When operating one of the levers, always be sure to turn the crank arm at the same time.

To shift from a small chainring to a larger chainring
When lever (A) is pressed once, there is a shift of one step from a small chainring to a larger chainring.

Example:
from intermediate chainring to largest chainring.

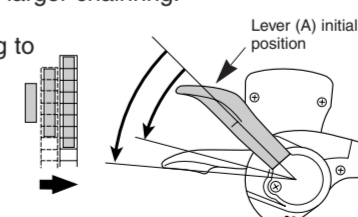

Replacement of the shifting lever unit and indicator

Disassembly and reassembly should only be carried out when replacing the indicator.

Removal of the indicator

- Remove the two indicator set screws which are securing the indicator.

Tightening torque : 0.3 - 0.5 Nm {3 - 4 in. lbs.}

- Remove the indicator unit as shown in the illustration.

- Operate lever (B) two times or more to set the lever to the lowest position.

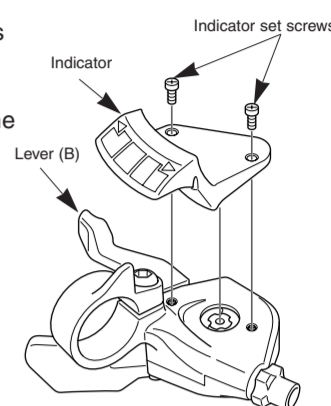

- After checking that the indicator needle is at the right edge, install the indicator as shown in the illustration.

- Check the operation of the indicator. If it does not operate correctly, re-install the indicator by while taking particular note of steps 3. and 4.

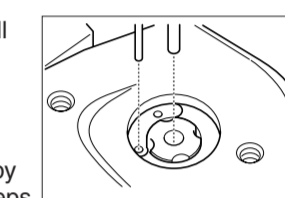

Disassembly and reassembly should only be carried out when replacing the shifting lever unit.

Replacement of the shifting lever unit

- Loosen the cable fixing bolt (nut) of the front derailleur, and then pull the inner cable out of the shifting lever unit in the same way as when installing the inner cable.
- Carry out steps 1 - 2 for replacement of the indicator.
- Remove the three shifting lever mounting screws, and then remove the shifting lever unit as shown in the illustration.

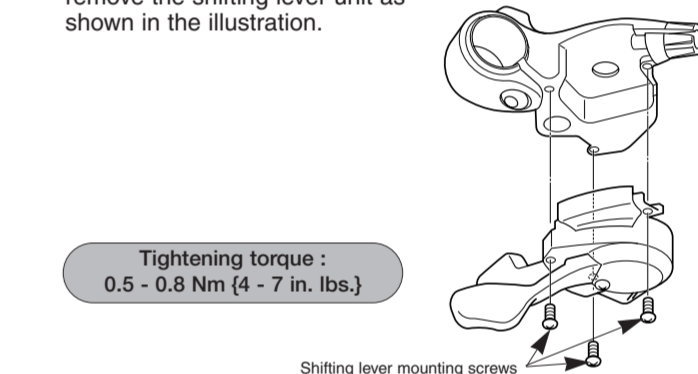

Tightening torque :
0.5 - 0.8 Nm {4 - 7 in. lbs.}

- To assemble, align the shifting lever unit and the brake lever bracket and then secure the shifting lever mounting screws.
- Carry out steps 3 - 4 for replacement of the indicator.

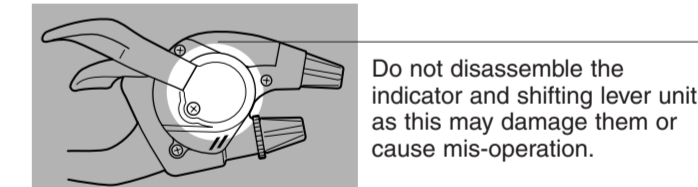

Do not disassemble the indicator and shifting lever unit, as this may damage them or cause mis-operation.

This service instruction explains how to use and maintain the Shimano bicycle parts which have been used on your new bicycle. For any questions regarding your bicycle or other matters which are not related to Shimano parts, please contact the place of purchase or the bicycle manufacturer.

SHIMANO®

SHIMANO AMERICA CORPORATION
One Holland Avenue CA 92618 U.S.A. Phone 949-951-5003

SHIMANO EUROPA
Industrieweg 24 NL-8071 CT Nunspeet Holland Phone 31-341-27222

SHIMANO INC.
77 Omiya-cho 3-chō Sakai Osaka 590-8577 Japan Phone 0722-23-3243

Please note: specifications are subject to change for improvement without notice. (English)

©Jun. 2000 by Shimano Inc. XBC X3C Printed in Japan

These service instructions are printed on recycled paper and can be recycled again.